

## Introduction

Quick CF (QCF) components and the appropriate clamp chains VaCFix® are developed by VACOM. The new QCF flanges combine the sealing principle of ConFlat® flanges with the simple mounting principle of KF connections. They fully comply with the UHV demands such as a leakrate <math> < 1.0E-11 \text{ mbar l/s}</math> and bakeability to 350 °C. Standard CF copper gaskets can be used for all dimensions.

QCF components can be assembled quick, easy and space saving. They can be connected to all existing vacuum systems by adapters. VaCFix® clamp chains are compatible with KF and conical ISO flanges. QCF components and clamp chains are available in the following dimensions: DN 16, 40, 63 and 100. Other dimensions on request.



Sealing principle QCF flanges with clamp chain

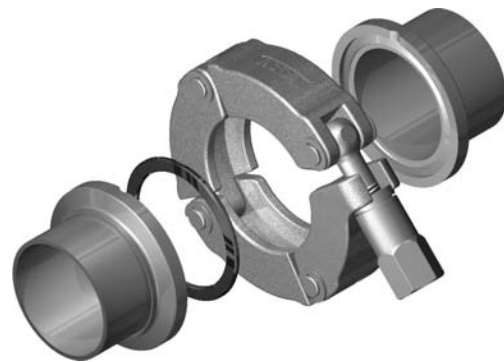

Exploded drawing assembly parts



XS40



XS100

## Application

- QCF use the proven OFHC flat seals of ConFlat® flanges
- The VaCFix® clamp chains generate a most uniform tightening torque on the flange by using a torque wrench. This fact is very beneficial for stress-sensitive flange components.
- Copper seals can be used up to three times in case of defined torque increase.
- Clamp chains up to DN63 can be assembled with one, from DN100 with two bolts.
- The very short assembly time is a significant advantage in case of frequently opened flange connections.
- The assembly of clamp chains is much more convenient than of conventional bolt connections especially in case of limited space
- Components with QCF flange can be assembled such as rotatable flanges in any angle position
- QCF components are bakeable to 350 °C

## Materials

Flanges	Tubes	Clamp Chains
stainless steel 1.4301	stainless steel 1.4301	non-magnetic stainless steel
stainless steel 1.4404 (on request)	stainless steel 1.4404	
stainless steel 1.4429 (on request)		

## Quick CF Flanges

1

### Quick CF Blank flanges, conical, stainless steel

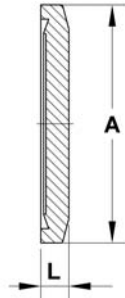

Order code	DN	A	L
QCF16-304	16	30	6.5
QCF40-304	40	55	6.5
QCF63-304	63	87	7.5
QCF100-304	100	134	14

- Other nominal widths on request
- For clean room compatible packaging please add "-CRP" to the order code

### Quick CF Bored flanges, conical, stainless steel

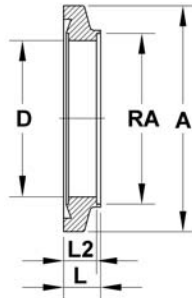

Order code	DN	A	RA	L	L2	D
QCF16B19-304	16	30	19	10	8	16
QCF40B38-304	40	55	38	10	8	35
QCF40B41-304	40	55	41	10	8	38
QCF63B63-304	63	87	63	11	10	61
QCF63B70-304	63	87	70	11	10	63
QCF100B101-304	100	134	101	19	17	98
QCF100B104-304	100	134	104	19	17	100

- Other nominal widths on request
- For clean room compatible packaging please add "-CRP" to the order code

### Quick CF Flange caps, plastics



Order code	DN
QCF16CAP	16
QCF40CAP	40
QCF63CAP	63
QCF100CAP	100

- 10 pieces per packing unit

## Quick CF Fittings

### Quick CF Tube, 1 m length, stainless steel

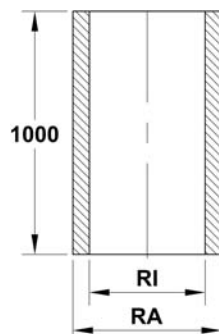

#### Technical data

- DIN 11850
- Lengthwise welded
- Outside and inside etched
- Ra < 0.8 μm
- Ra (welding seam area) < 1.6 μm

Order code		DN	RI	RA
Stainless steel 316L	Stainless steel 304			
R316-19x1.5-1	R304-19x1.5-1	16	16	19
R316-41x1.5-1	R304-41x1.5-1	40	38	41
R316-70x2.0-1	R304-70x2.0-1	63	66	70
R316-104x2.0-1	R304-104x2.0-1	100	100	104

## Quick CF Fittings

### Quick CF Tubulations (half nipples), stainless steel

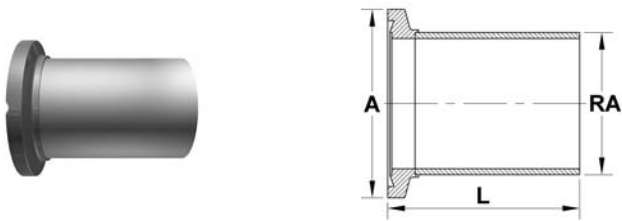

Order code	DN	A	L	RA
TU16QCF-304	16	30	38	19
TU40QCF-304	40	55	63	41
TU63QCF-304	63	87	105	70
TU100QCF-304	100	134	135	104

- For clean room compatible packaging please add "-CRP" to the order code

### Quick CF Straight connectors (full nipples), stainless steel

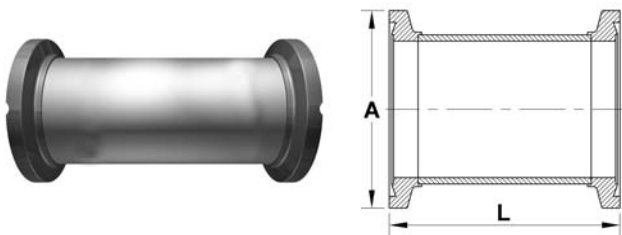

Order code	DN	A	L
SC16QCF-304	16	30	76
SC40QCF-304	40	55	126
SC63QCF-304	63	87	210
SC100QCF-304	100	134	270

- For clean room compatible packaging please add "-CRP" to the order code

### Quick CF to CF Adapters, stainless steel

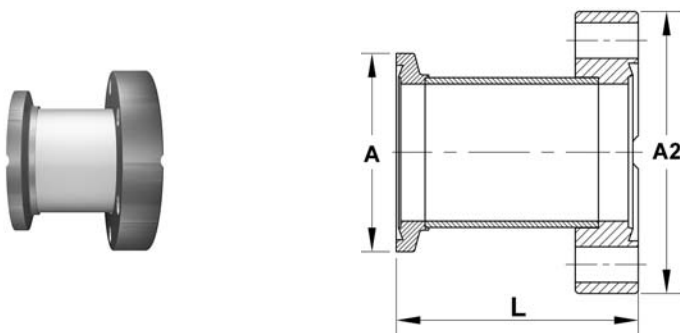

Order code	DN	A	A2	L
QCFA16-304	16	30	34	50
QCFA40-304	40	55	70	60
QCFA63-304	63	87	114	90
QCFA100-304	100	134	152	100

- For clean room compatible packaging please add "-CRP" to the order code

### Quick CF Elbows 90°, stainless steel

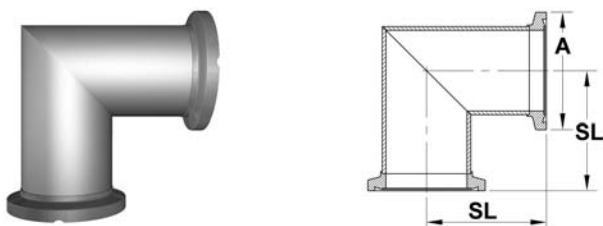

Order code	DN	A	SL
EL16QCF-304	16	30	38
EL40QCF-304	40	55	63
EL63QCF-304	63	87	105
EL100QCF-304	100	134	135

- For clean room compatible packaging please add "-CRP" to the order code

## Quick CF Fittings

1

### Quick CF Tees, stainless steel

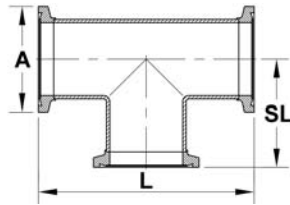

Order code	DN	A	L	SL
TE16QCF-304	16	30	76	38
TE40QCF-304	40	55	126	63
TE63QDF-304	63	87	210	105
TE100QCF-304	100	134	270	135

- For clean room compatible packaging please add "-CRP" to the order code

### Quick CF 4-way crosses, stainless steel

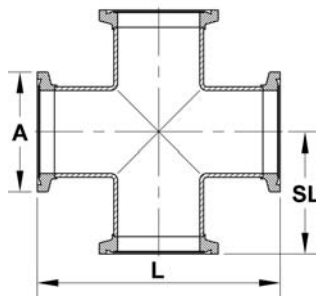

Order code	DN	A	L	SL
X16QCF-304	16	30	76	38
X40QCF-304	40	55	126	63
X63QCF-304	63	87	210	105
X100QCF-304	100	134	270	135

- For clean room compatible packaging please add "-CRP" to the order code

### Quick CF 6-way crosses, stainless steel

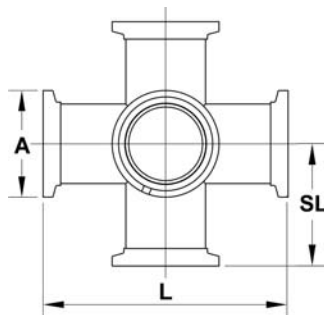

Order code	DN	A	L	SL
XX16QCF-304	16	30	76	38
XX40QCF-304	40	55	126	63
XX63QCF-304	63	87	210	105
XX100QCF-304	100	134	270	135

- For clean room compatible packaging please add "-CRP" to the order code

## Quick CF Gaskets

### Quick CF Copper gaskets

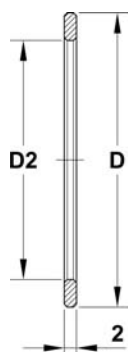

#### Technical data

- Material OFHC copper
- Hardness ca. 85 Brinell
- Bakeout temperature to 450 °C
- Packing unit 10 pieces

Order code	DN	D	D2
CU16	16	21	16
CU40	40	48	39
CU63	63	82	63
CU100	100	120	101

- For clean room compatible packaging please add "-CRP" to the order code

## Quick CF Gaskets

### Quick CF Copper gaskets, vacuum-annealed

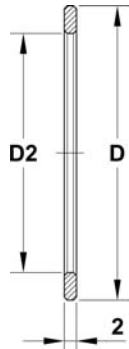

#### Technical data

- Material OFHC copper
- Hardness ca. 45 Brinell
- Bakeout temperature to 450 °C
- Application feedthroughs, viewports, glass-to-metal connections
- Packing unit 5 pieces

Order code	DN	D	D2
CUA16	16	21	16
CUA40	40	48	39
CUA63	63	82	63
CUA100	100	120	101

- For clean room compatible packaging please add "-CRP" to the order code

### Quick CF Copper gaskets, silver plated

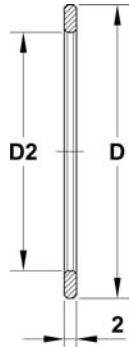

#### Technical data

- Material OFHC copper
- Hardness ca. 85 Brinell
- Bakeout temperature to 450 °C
- Packing unit 5 pieces

Order code	DN	D	D2
CU16SP	16	21	16
CU40SP	40	48	39
CU63SP	63	82	63
CU100SP	100	120	101

- For clean room compatible packaging please add "-CRP" to the order code

### Quick CF Copper gaskets, silver plated, vacuum-annealed

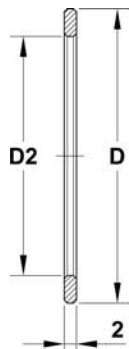

#### Technical data

- Material OFHC copper
- Hardness ca. 45 Brinell
- Bakeout temperature to 450 °C
- Packing unit 5 pieces

Order code	DN	D	D2
CUA16SP	16	21	16
CUA40SP	40	48	39
CUA63SP	63	82	63
CUA100SP	100	120	101

- For clean room compatible packaging please add "-CRP" to the order code

## Quick CF Gaskets

1

### Quick CF Flat gaskets, FKM

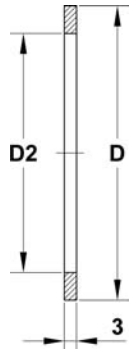

#### Technical data

- Temperature range -10 °C bis 150 °C (intermitted 200 °C)
- Application multiple use possible

Order code	DN	D	D2
<b>VGf16</b>	16	21	16
<b>VGf40</b>	40	48	37
<b>VGf63</b>	63	82	63
<b>VGf100</b>	100	120	101

## Quick CF Connecting Elements

### Quick CF Clamp chains, stainless steel

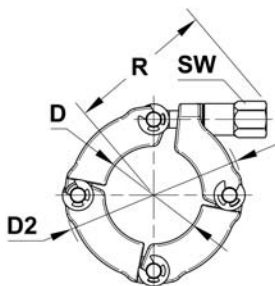
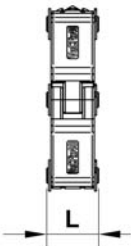

#### Technical data

- Material stainless steel non-magnetic
- Suitable flanges QCF flanges  
KF flanges  
conical ISO flanges
- Suitable seals copper gaskets  
FKM seals
- Assembly with torque wrench
- Accessories spares (eye screw nut)  
heating sleeve on request

Order code	DN	D	D2	R	L	Number of links	SW	Weight (g)
<b>XS16</b>	16	21	53	47	24	3	13	220
<b>XS40</b>	40	46	82	67	24	4	15	430
<b>XS63</b>	63	73	121	89	28	5	19	980
<b>XS100</b>	100	117	176	117	41	6	24	2540

- For clean room compatible packaging please add "-CRP" to the order code