

# Bourdon Tube Pressure Gauges with Electrical Output Signal Stainless Steel, Safety Pattern Version Model PGT23.063

WIKA Data Sheet PV 12.03



**intelliGAUGE®**

## Applications

- Acquisition and display of process values
- Transmission of process value to the control room, 4 ... 20 mA
- Easy-to-read, local analogue display needs no power supply
- Safety-related applications

## Special Features

- „Plug and play“ means no configuration necessary
- Measuring ranges from 0 ... 1 bar to 0 ... 600 bar
- Easy-to-read, nominal size 63 analogue display
- S3 Safety pressure gauge per EN 837-1



**intelliGAUGE Model PGT23.063**

## Description

At any point with limited space, where the process pressure has to be indicated locally, and, at the same time, a signal is wanted to be transmitted to a central controller or remote control room, the model PGT23.063 intelliGAUGE can be used.

Through the combination of a mechanical measuring system and electronic signal processing, the process pressure can be read securely, even if the power supply is lost. The model PGT23.063 intelliGAUGE fulfils all safety-related requirements of the relevant standards and regulations for the on-site display of the operating pressure of pressure vessels. An additional measuring point for the mechanical pressure indication can thus be saved.

The model PGT23.063 is built upon a high-quality, stainless steel pressure gauge in safety pattern version model 23x.30 with nominal size of 63. The pressure gauge is manufactured in accordance with EN 837-1.

The durable, fully-welded Bourdon tube measuring system produces a pointer rotation proportional to the pressure. An electronic angle encoder, proven in safety-critical automotive applications, determines the position of the pointer shaft – it is a non-contact sensor and therefore completely free from wear and friction. From this, the pressure-proportional, 4 ... 20 mA electrical output signal is produced.

The electronic WIKA transmitter, integrated into the high-quality mechanical pressure gauge, combines the advantages of electrical signal transmission with the advantages of a local mechanical display.

The measuring span (electrical output signal) is set automatically along with the mechanical display, i.e. the scale over the full display range corresponds to 4 ... 20 mA.

## Standard version

### Nominal size in mm

63

### Accuracy class

1.6

### Scale ranges

0 ... 1 up to 0 ... 600 bar

or all other equivalent vacuum or combined pressure and vacuum ranges

### Process connection

Stainless steel 316L,

lower mount (LM)

G ¼ B (male), 14 mm flats

### Pressure element

Stainless steel 316L,

< 100 bar: C-type

≥ 100 bar: helical type

### Movement

Brass

### Dial

Aluminium, white, black lettering

### Pointer

Aluminium, black

### Case

Stainless steel, with solid baffle wall and blow-out back, scale ranges ≤ 0 ... 16 bar with compensating valve to vent case, IP 54 ingress protection

### Window

Polycarbonate

### Bezel ring

Cam ring (bayonet type), stainless steel

### Connection

Free cable, length 1 m

## Options

- Other process connection
- Inverted electrical output signal
- Electrical connection via miniature plug connector M8 x 1, 4-pin (cable plug with 5 metre length)
- Other cable lengths, bare wire ends with 2 or 5 metre length. Others on request.
- Assembly on diaphragm seals (see Diaphragm Seals Product Review)
- Liquid filling Silicone M50 (only in assembly with plug connector)
- Panel mounting flange stainless steel or polished
- Rear mounting bracket, stainless steel
- Laminated safety glass window (max. ambient temperature 60 °C)

### Cable connection

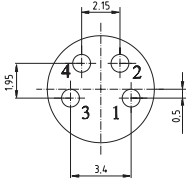
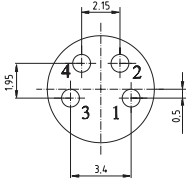
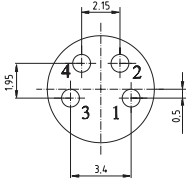

Electrical data

Power supply $U_B$	DC V	$12 < U_B \leq 30$																
Supply voltage effect	% v. FS/10 V	< 0.1																
Permissible residual ripple	% ss	< 10																
Output signal		4 ... 20 mA, 2-wire																
Permissible max. load $R_A$		$R_A \leq (U_B - 12 \text{ V})/0.02 \text{ A}$ with $R_A$ in Ohm and $U_B$ in Volt, however max. 600 $\Omega$																
Effect of load	% FS	$\leq 0.1$																
Accuracy																		
■ Long-term stability of electronics	% FS/a	< 0.5																
■ Electrical output signal		$\leq 1.6$ % of measuring span																
Linearity	% of span	$\leq 1.6$ % (limit point calibration) <sup>1)</sup>																
EMC directive		2007/108/EC Interference emission (Limit Class B) and immunity to EN 61 326-1																
Wiring		Free cable or as option miniature plug connector M8 x 1, 4-pin																
Wiring protection		IP 54 per EN 60 529 / IEC 529, filled IP 65																
Connection details		<table border="0"> <tr> <td>Cable</td> <td>Plug connector</td> <td>Meaning</td> <td rowspan="5">  </td> </tr> <tr> <td>red</td> <td>Pin 1</td> <td><math>U_B</math>+/Sig +</td> </tr> <tr> <td>black</td> <td>Pin 4</td> <td>0 V/Sig -</td> </tr> <tr> <td>brown</td> <td>Pin 2</td> <td>n.c.</td> </tr> <tr> <td>- - -</td> <td>Pin 3</td> <td>n.c.</td> </tr> </table>	Cable	Plug connector	Meaning		red	Pin 1	$U_B$ +/Sig +	black	Pin 4	0 V/Sig -	brown	Pin 2	n.c.	- - -	Pin 3	n.c.
Cable	Plug connector	Meaning																
red	Pin 1	$U_B$ +/Sig +																
black	Pin 4	0 V/Sig -																
brown	Pin 2	n.c.																
- - -	Pin 3	n.c.																

Mechanical data

Mechanical design		Safety pressure gauge with solid baffle wall
Display		Nominal size 63
Measuring ranges	bar	0 ... 1 bar up to 0 ... 600 bar; -1 ... 0; -1 ... +25 (others available as options)
Process connection		male G ¼ B (others available as options)
Damping options		
■ for dynamic pressure		through a dynamic pressure snubber in the pressure channel
■ for vibration		through fluid filling of the case
Pressure limitation		
■ Steady		3/4 x full scale value
■ Fluctuating		2/3 x full scale value
■ Short time		full scale value
		The recommendations for the use of mechanical measuring systems in accordance with EN 837-1 must be observed
Accuracy		
■ Mechanical display		$\leq 1.6$ % of measuring span (Class 1.6 to EN 837-1) <sup>1)</sup>
Permissible temperature range of		
■ Medium	°C	-40... +100
■ Ambience	°C	-40 ... +80 (for laminated safety glass window max. 60 °C)
Temperature influence		max. 0.4 % of measuring span /10 K (when temperature of the pressure element deviates from +20 °C reference temperature)
Ingress protection (front panel)		IP 54, filled IP 65
■ Pressure Equipment Directive		97/23/EC

1) For technical reasons, up to the first scale marking, the measured value can lie outside of the class accuracy.

## Dimensions in mm

### Standard version

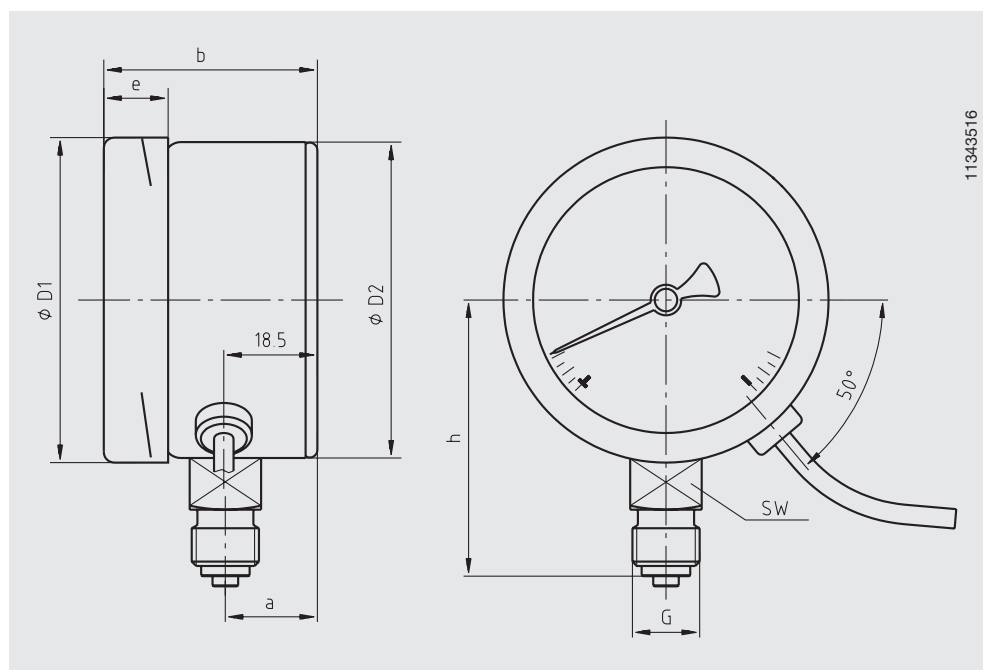

NS	Dimensions in mm								Weight in kg
	a	b	D1	D2	e	G	h±1	SW	
63	18	42	63	62	14.5	G ¼ B	54	14	0.25

### Ordering information

Model / Scale range / Connection size / Connection location / Output signal / Options

Specifications and dimensions given in this leaflet represent the state of engineering at the time of printing. Modifications may take place and materials specified may be replaced by others without prior notice.



**WIKAI Alexander Wiegand GmbH & Co. KG**  
 Alexander-Wiegand-Straße 30  
 63911 Klingenberg/Germany  
 Tel. (+49) 9372/132-0  
 Fax (+49) 9372/132-406  
 E-mail info@wika.de  
 www.wika.de