

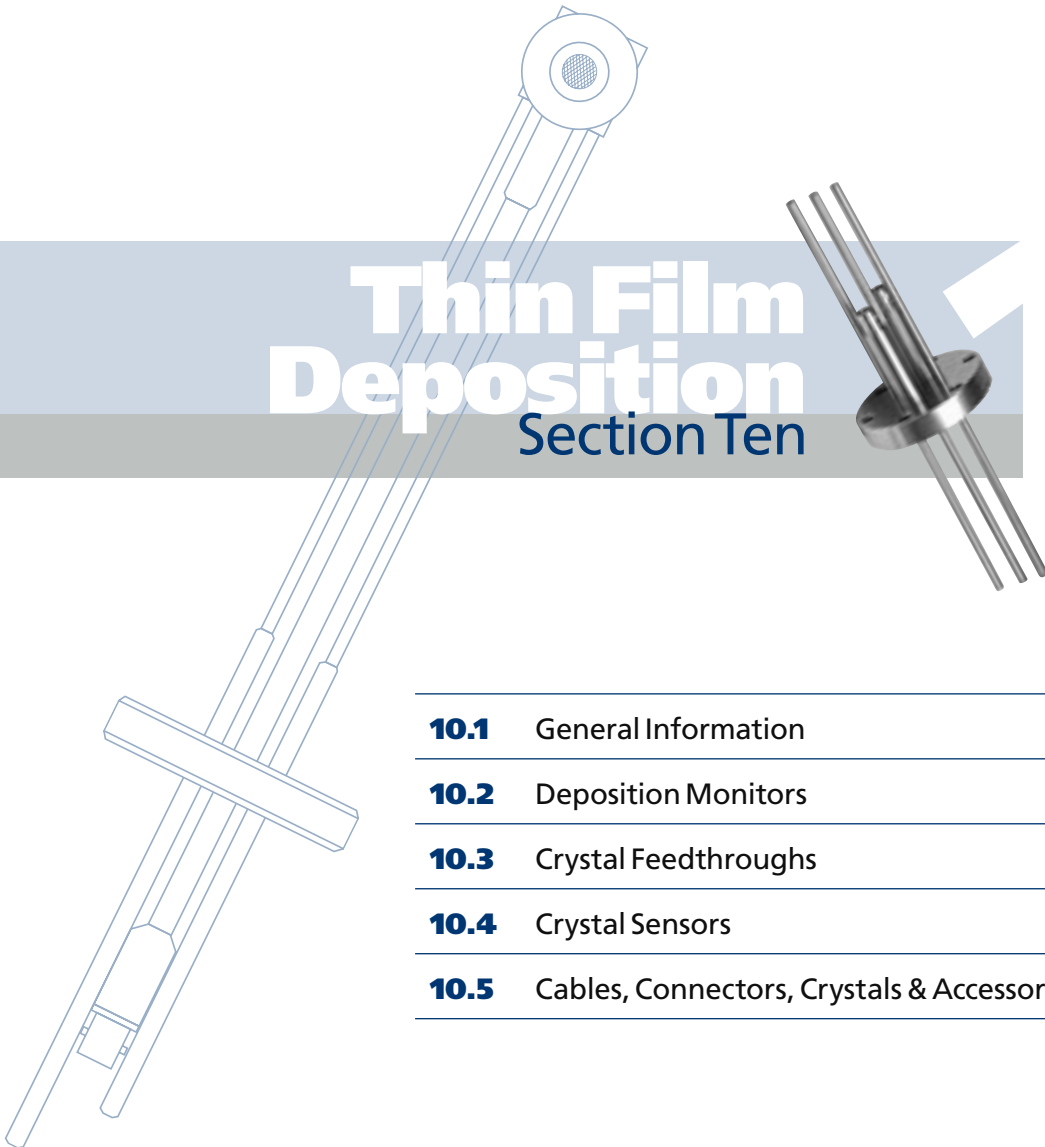

Thin Film Deposition

Section Ten



10.1	General Information	2
10.2	Deposition Monitors	3
10.3	Crystal Feedthroughs	4
10.4	Crystal Sensors	5
10.5	Cables, Connectors, Crystals & Accessories	6

Nor-Cal Products, Inc.
P. O. Box 518
1967 So. Oregon
Yreka, CA 96097 USA

Tel: **800-824-4166**
or 530-842-4457
Main Fax: 530-842-9130
Sales Fax: 530-841-9189
www.n-c.com



Thin Film Deposition

General Information

Nor-Cal offers an extensive selection of commonly used quartz crystal feedthroughs, sensors and multi-channel monitors, cables, quartz crystals, accessories and replacement parts for use in semiconductor, optical and industrial thermal deposition processes. Custom feedthroughs are available with a variety of flanges in all sizes.

Our coating instrumentation products support one of the more popular methods of thin film measurement and rate control - the crystal monitor, which utilizes the piezo-electric properties of a quartz crystal.

The electrical characteristics of the crystal, which is held in place by the sensor, change during deposition. Single sensors are generally used for short deposition runs, whereas, dual sensors allow for longer runs. Dual sensors require an air line to operate a pneumatic shutter which covers one crystal at a time. The sensor is either welded to the feedthrough or attached with connectors. Most sensors are available with cooling lines.

The application determines the correct choice of sensor. The sensor determines compatible feedthroughs and cabling. The chamber determines the appropriate feedthrough and flange. For application temperatures up to 150°C,



electrical connection between the sensor and feedthrough is accomplished with a vacuum coaxial cable. A bakeable, one piece sensor/feedthrough replaces the standard in-vac cable with a stainless steel high-temp coaxial line for high temperature applications up to 300°C.

The feedthrough is the air-to-vacuum connection between the sensor and the oscillator. The feedthrough transfers the quartz crystal's piezo-electric vibrations to the oscillator via a short coaxial cable. The oscillator conditions the signals

and transfers them to the monitor via another coaxial cable. The monitor then measures, interprets and displays the thickness, rate and frequency of deposition. Nor-Cal's thin film deposition monitors are available with up to six independent channels to read six sensors. Each sensors' rate, thickness and frequency can be read from the RS-232 port, and placed in a spreadsheet formatted file for later inspection. Each sensor requires its own cabling and oscillator. Contact our sales staff for help with your system configuration.

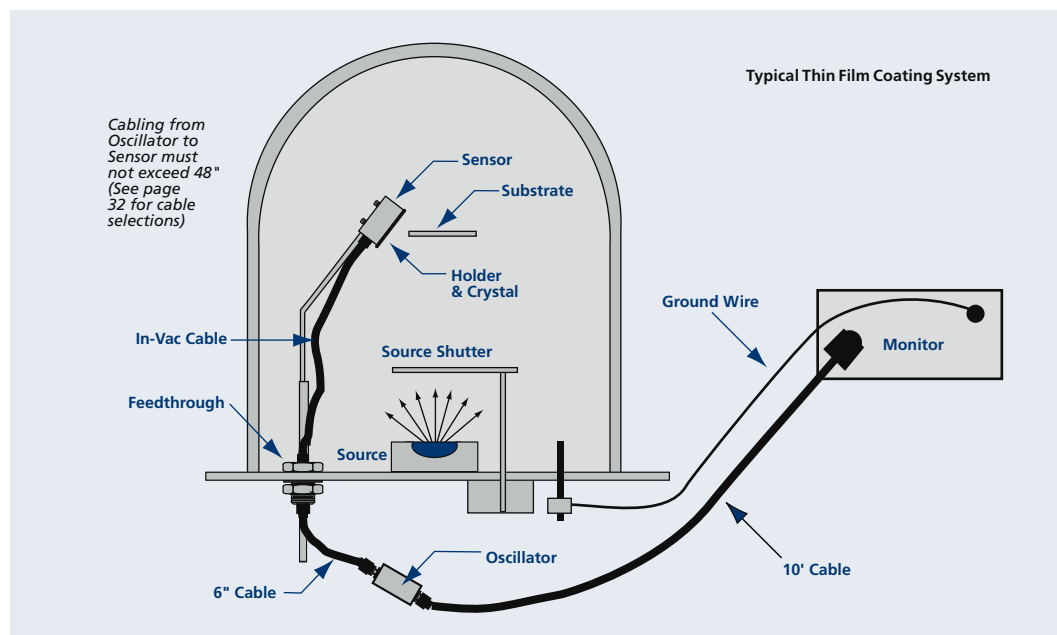

All dimensions are in inches unless otherwise noted

Prices subject to change without notice. - International product pricing will vary.

Ultra-High Vacuum Components Since 1962 • 800-824-4166 • www.n-c.com





Deposition Monitors

Our deposition monitors measure film thickness/rate or frequency using crystals as the sensor device. Independent channels monitor different films or average different sensors together to provide a more uniform deposition measurement. These monitors are Class 1 Equipment CE approved. Included are a RS-232 cable and Windows software. This software will allow you to change the monitor's parameters, save process readings in Excel formatted files, and operate the the monitor remotely. Mounting brackets are included, rack-mount extenders are available on request

MODEL NUMBER	CRYSTAL INPUTS	POWER INPUT	TEMPERATURE RANGE	FREQUENCY RANGE
CM-2	2	120/240 VAC, 20 VA	0° to 50°C	6.0 to 4.0 MHz
CM-6	6	120/240 VAC, 20 VA	0° to 50°C	6.0 to 4.0 MHz

SPECIFICATIONS

- Dimensions:** 8.38x3.50x7.75 inches
- Connections**
Inputs: 4 digital, 2 or 6 sensor
Outputs: 4 relay, analog rate & thickness
PC: RS-232 port
- Display:** Alphanumeric LED
- Frequency:** 6.0 to 4.0 MHz, programmable
- Rate averaging:** 1 to 20 readings
- Frequency resolution:** 0.1 Hz
- Thickness resolution:** 1 Å
- Rate resolution:** 0.1 or 0.01 Å/s selectable
- Measurement rate:** 0.15 to 2 seconds

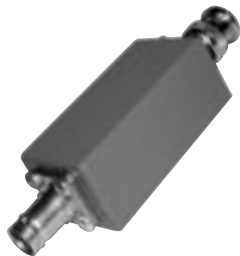

Remote Oscillators

Oscillators condition the signal from the crystal sensor to the controller. They are housed in a die-cast aluminum body. BNC connectors are used to interface with the monitor and sensor. Refer to the diagram on this page for installation and to page 194 of the catalog for cabling and accessories. In-vacuum oscillators are available. Call for information and pricing.

MODEL NUMBER	TEMPERATURE RANGE	FREQUENCY RANGE
CO-A	10° to 40°C	6.0 to 4.0 MHz

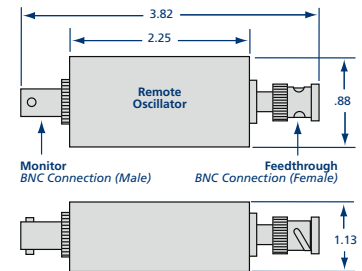

Thin Film Deposition Crystal Feedthroughs



SPECIFICATIONS

Materials	Feedthrough: 304 stainless steel
Vacuum range:	$\geq 1 \times 10^{-9}$ Torr - High vacuum
Temperature range:	$\leq 150^\circ\text{C}$
Leak rate:	$\leq 10^{-9}$ standard cc/sec
Baseplate thickness:	1 inch maximum



1 Inch Bolt Crystal Feedthroughs

MODEL NUMBER	SENSOR CONNECTIONS	IN VAC CONNECTOR	EXTERNAL CONNECTOR	COOLING LINES	COMPRESSION FITTINGS	AIR LINES
CF-100-1	1	Microdot	BNC	-	-	-
CF-100-1-W	1	Microdot	BNC	2	-	-
CF-100-1-WC	1	Microdot	BNC	2	✓	-
CFP-100-2-W	2	Microdot	Microdot	2	-	1

Note: 1.25 inch bolt feedthroughs are available. Call for pricing.

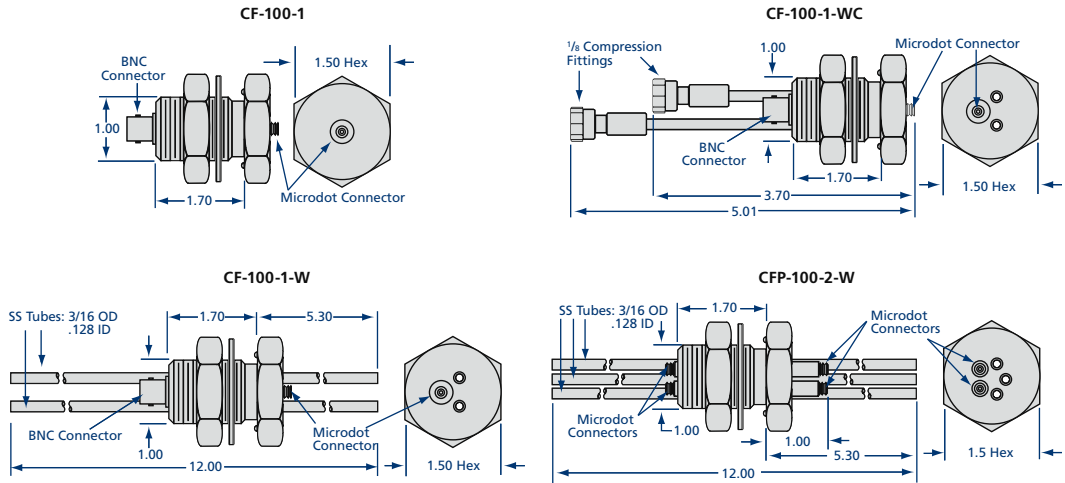

CF Flanged Crystal Feedthroughs

SPECIFICATIONS

Materials	Flanges: 304 stainless steel Flange sizes: 1 1/3 to 2 3/4 CF Feedthrough: 304 stainless steel
Vacuum range:	$\geq 1 \times 10^{-9}$ Torr - High vacuum
Temperature range:	$\leq 150^\circ\text{C}$
Leak rate:	$\leq 10^{-9}$ standard cc/sec



MODEL NUMBER	FLANGE TYPE	SENSOR CONNECTIONS	IN VAC CONNECTOR	EXTERNAL CONNECTOR	COOLING LINES	COMPRESSION FITTINGS	AIR LINES
CF-133-1	1.33 CF	1	Microdot	BNC	-	-	-
CF-275-1-W	2.75 CF	1	Microdot	BNC	2	-	-
CF-275-1-WC	1.33 CF	1	Microdot	BNC	2	✓	-
CFP-275-2-W	2.75 CF	2	Microdot	Microdot	2	-	1

Note: ISO, NW, and ASA flanged feedthroughs are available upon request. Call for pricing.

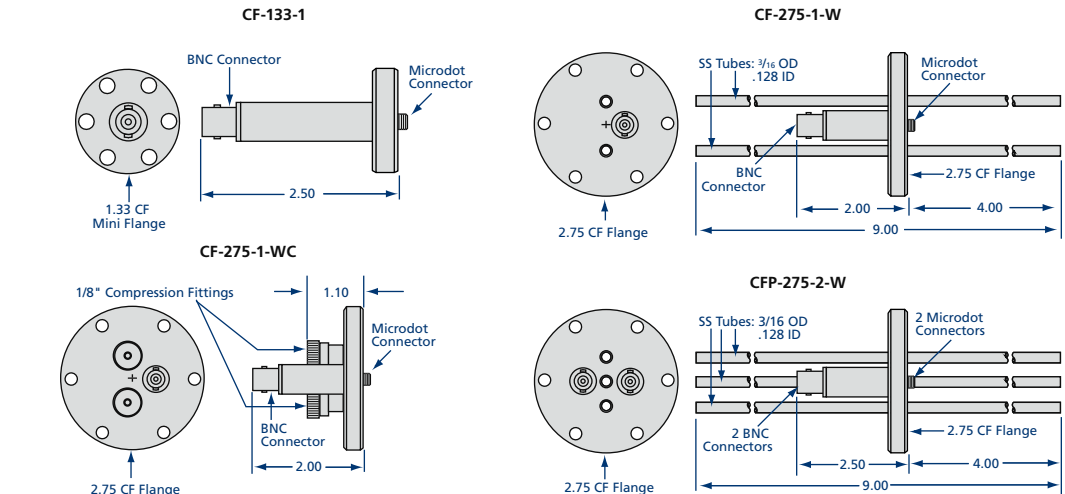

Prices subject to change without notice. - International product pricing will vary.

Single Crystal Sensors

MODEL NUMBER	SENSORS	MOUNTING BRACKET	SENSOR ORIENTATION	WATER COOLED
CS-1	1	✓	0°	
CS-1-W	1		0°	✓
CS-1-W-RA	1		90°	✓

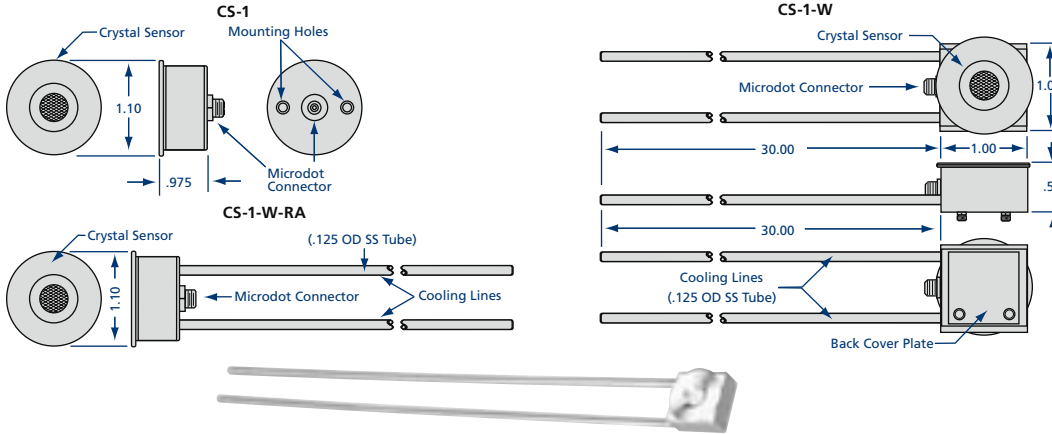

SPECIFICATIONS

Materials
 Body: 304 stainless steel
 Crystals: 6 MHz gold and aluminum alloy

Vacuum range: $\geq 1 \times 10^{-9}$ Torr - High Vacuum

Temperature range: $\leq 225^\circ\text{C}$

Custom lengths and bends available for all sensors.

Cables, crystals and accessories are on page 194.

Dual Crystal Sensors

MODEL NUMBER	SENSORS	SENSOR ORIENTATION	PNEUMATIC SHUTTER	WATER COOLED
CSP-2-W	2	0°	✓	✓
CSP-2-W-RA	2	90°	✓	✓

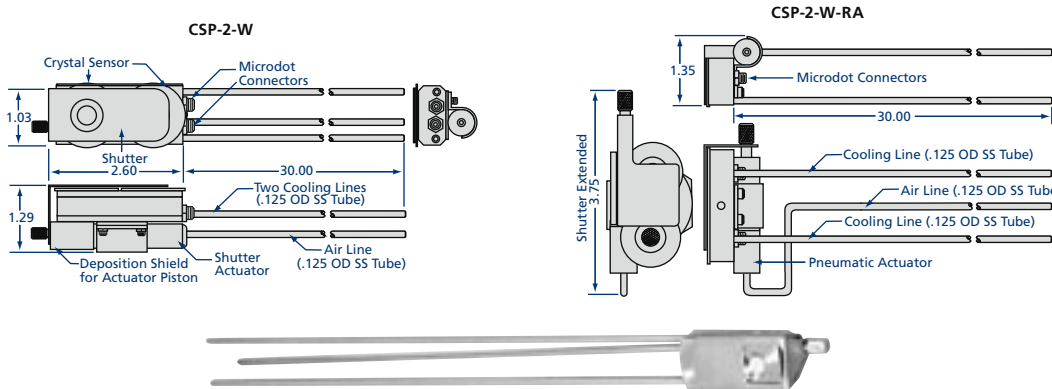

Bakeable Crystal Sensors

MODEL NUMBER	FLANGE TYPE	DESCRIPTION	TEMPERATURE RANGE	WATER COOLED
CSH-275-1-W	2.75 CF	Single sensor with feedthrough	$\leq 300^\circ\text{C}$	✓

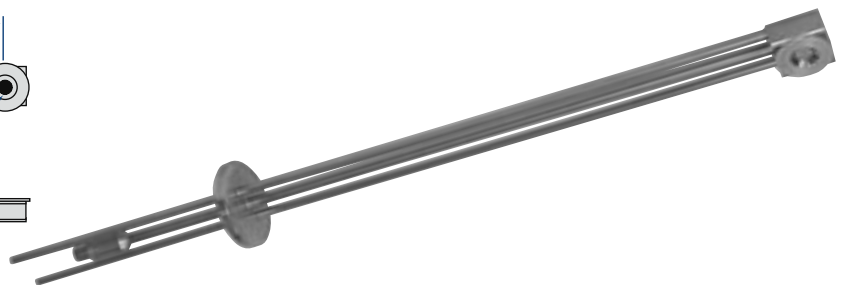
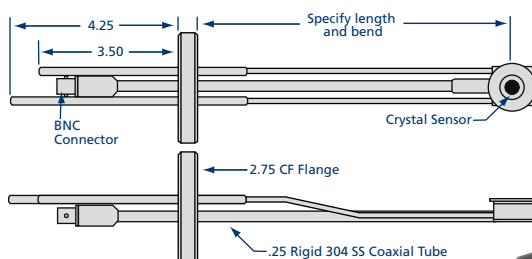

Thin Film Deposition

Cables, Connectors, Crystals & Accessories



Cables and Connectors

MODEL NUMBER	DESCRIPTION	LENGTH
CCV-MM-30*	Microdot to Microdot in-vacuum coaxial cable, metal sheath. Connects feedthrough to sensor.	30.75*
CCV-MM-30T*	Microdot to Microdot in-vacuum coaxial cable, Teflon coated metal sheath. Connects feedthrough to sensor.	30.75*
CCA-BB-6	BNC to BNC cable (Male to Female). Connects feedthrough to oscillator.	6.00
CCA-BM-6	BNC to Microdot cable. Connects feedthrough to oscillator.	6.00
CCA-BB-10	BNC to BNC cable (Male to Male). Connects oscillator to monitor.	120.00
CRU-1	Reducing union tube connector $\frac{3}{16}$ to $\frac{1}{8}$. Connects cooling and air lines between feedthrough and sensor	Each

*Add \$13.00 for Special Lengths



Quartz Crystals and Accessories

MODEL NUMBER	DESCRIPTION	QUANTITY
CQ-G	6MHz gold, .550 diameter	Pkg. of 10
CQ-A	6MHz aluminum alloy, .550 diameter	Pkg. of 10
CH-1	Replacement crystal holder	Each

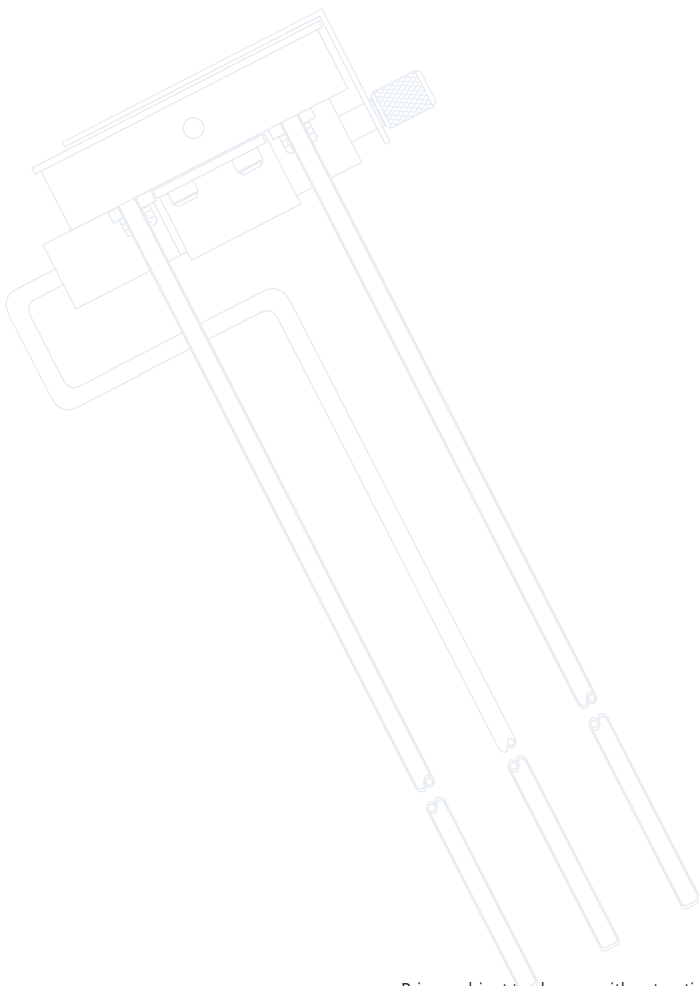

Prices subject to change without notice. - International product pricing will vary.